

Leave answer in simplified radical form and then change to whole #.

Special Triangles 8 – More Practice

8.08

Use special angle relationships to find the missing sides and heights. Then change the radicals to decimals rounded to the nearest tenth. Then find the area and perimeter of each figure, rounding final answers to the nearest whole number.

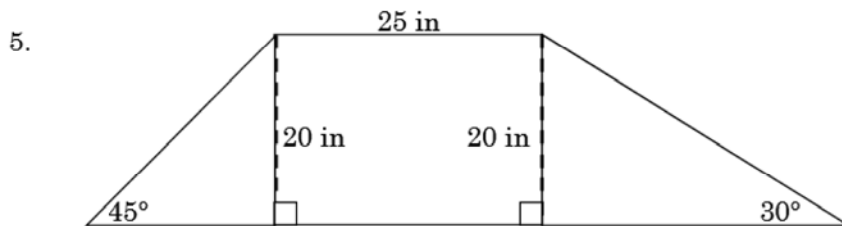
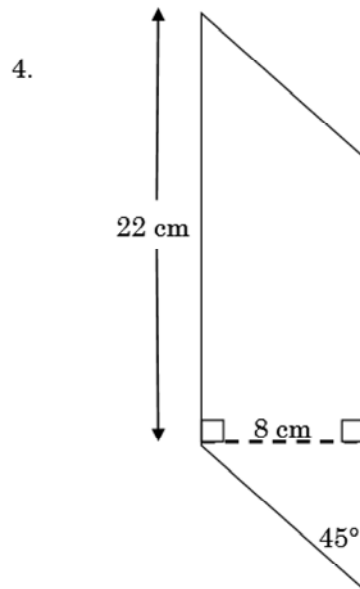
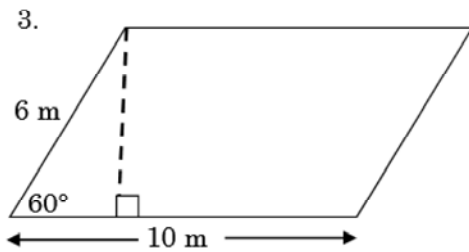
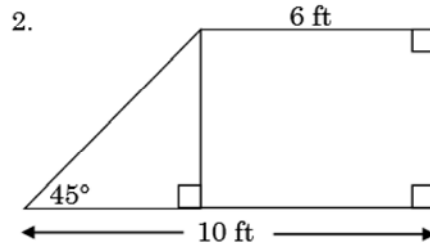
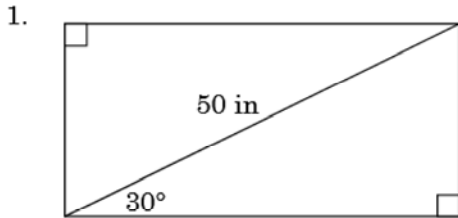

Scrambled answers: 26, 32, 32, 52, 67, 137, 173 176, 1046, 1083